

4

3

2

1

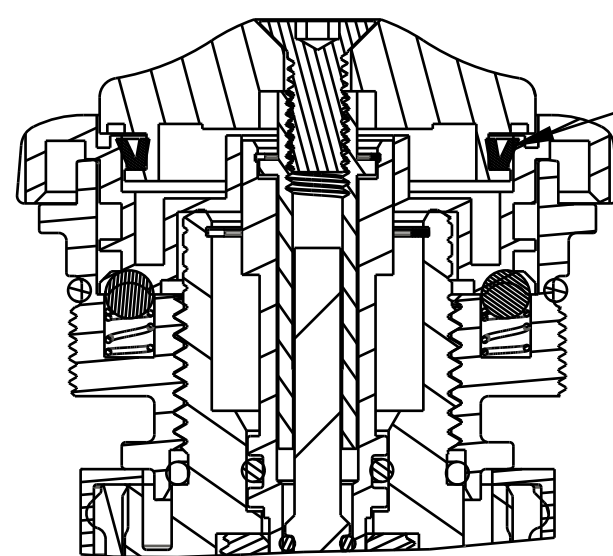

IMPORTANT:  
NOTE ORIENTATION OF  
U-CUP SEALS

241-00-020  
Fastener, Custom: Cover, Nut 011 RC2

210-03-120  
Knob, Rebound, 2011 36\_40

241-00-022  
Fastener, Custom: Nut, Bottom, 011 RC2

241-01-011  
Fastener, Custom: Crush Washer, Plastic, 13mm

TORQUE:  
5±1 IN.LB.

018-01-007  
Socket Set Half Dog Point Screw [#8-32 X 0.250 TLG]

029-08-053  
Seals: O-Ring [15mm ID x 1.5mm CS] Metric, N-70, Static

TORQUE:  
65±5 IN.LB.

REFERENCE ONLY  
(FOR INSTALLATION INTO FORK)

CARTRIDGE ASSY

REFERENCE ONLY  
(FOR INSTALLATION INTO FORK)

TORQUE:  
220±5 IN.LB.

039-00-005  
Spring: [0.125 TLG X 0.125 OD X 36.45 lbs/in]

GREASE:  
THIN LAYER ON MATING  
OF SLICK HONEY

010-01-000  
Ball [Ø 0.1250] Steel

210-03-194  
Knob, High Speed, Compression, 2014 RC2

036-01-074  
Seal: U-Cup, Shore 70A, 2014 RC2, Low-Speed

210-03-193  
Knob, Low Speed, Compression, 2014 RC2

019-01-060  
Fastener, Standard (Metric): Screw [M4 X 10mm] Socket Flathead, Patchlock

GREASE:  
THIN LAYER ON MATING  
KNOB SURFACES

GREASE:  
THIN LAYER ON MATING  
OF SLICK HONEY

GREASE:  
THIN LAYER

TORQUE:  
11±3 FT.LB.

**FOX** FOX Factory, Inc. Ph 831-768-1100  
130 Hangar Way, Watsonville, CA 95076 USA Fax 831-768-9312

TITLE  
**Assembly Drawing: 2015 36  
RC2 Cartridge, Complete**

SIZE DWG. NO.  
**C**

PLOT SCALE 0.50:1

SHEET 1 OF 1

PROPRIETARY  
THIS DOCUMENT CONTAINS CONFIDENTIAL, PROPRIETARY INFORMATION  
THAT IS FOX PROPERTY. DO NOT DISCLOSE TO OR DUPLICATE  
FOR OTHERS EXCEPT AS AUTHORIZED BY FOX.

ProE ASSEM